



SOLUTIONS FOR

Barriers

- Barriers
- Accessories for barriers



Levixo 30 / 50 RTS

Barriers

UP TO 5 M



Road barriers robust, durable and suitable for intensive use.

- Two models:
 - > 3 metres – opening in 4 seconds
 - > 5 metres – opening in 8 seconds
- Suitable for intensive use up to 1200 cycles/day
- An extensive range of accessories for a professional installation
 - > Anchor base for concrete foundation
 - > Boom rest fork
 - > Photoelectric-cell mounting columns
 - > Protection rubber for boom

Packs

						Packs per pallet
Levixo 30 motor	Levixo 50 motor	Control box Levixo RTS	Levixo boom 3 m Ref. 9017041	Levixo boom 5 m Ref. 9017042	Boom rest fork Ref. 9017044	

Levixo 30 RTS Ref. 1216339	●	-	●	-	-	-	6
Levixo 50 RTS Ref. 1216340	-	●	●	-	-	-	6
Levixo boom 30 Ref. 9017041	-	-	-	●	-	-	24
Levixo boom 50 Ref. 9017042	-	-	-	-	●	-	24
Levixo rest fork Ref. 9017044	-	-	-	-	-	●	30



Standard installation

1. Levixo 30/ 50 motor
2. Control box
3. Boom
4. Boom rest fork
5. Amber light
6. Outdoor antenna
7. Column for photocell

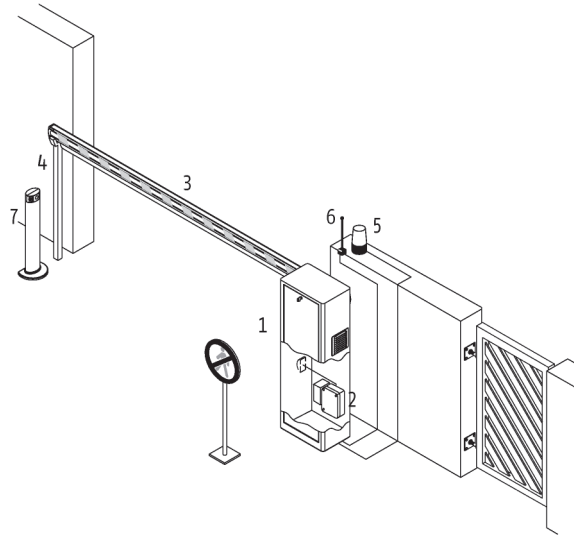

General overall size

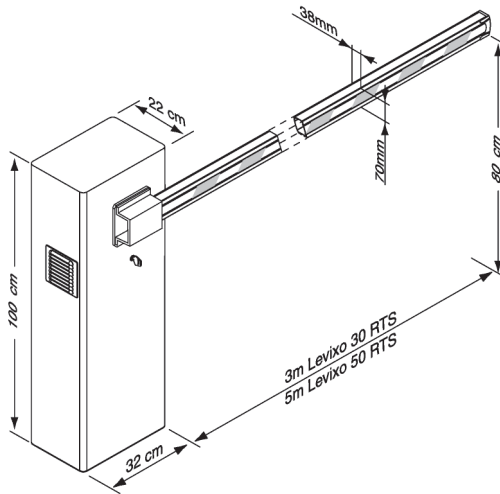

Technical characteristics

Motor power supply	230 V		Opening time	3 m	4 sec
Maximum power consumption	300 W			5 m	8 sec
Accessory supply output	24 V / 180 mA		RTS remote control frequency	433.42 MHz	
Maximum number of operations/day	3 m	1200	Number of remote controls that can be memorized	36	
	5 m	600	Index of protection	IP 24	
Motor torque	3 m	85 Nm	Operating temperature	-10°C to +55°C	
	5 m	250 Nm	Tested for	3 m	2 million cycles
		5 m		1 million cycles	

Special accessories



Amber light Master Pro
230 V blinking
More information on page 126

Ref. 9015034



Photocells Master Pro
More information on page 127

Ref. 9014994



Columns
More information on page 66

Ref. 9017210



Protection rubber for boom
More information on page 66

Ref. 9017045

Accessories for barriers

SPECIAL ACCESSORIES FOR BARRIERS



Ref. 9017041

Boom 3 meter length (for Levixo 30)

Aluminium boom profile.

Weight tuned to barrier compensation spring.



Ref. 9017042

Boom 5 meter length (for Levixo 50)

Aluminium boom profile.

Weight tuned to barrier compensation spring.



Ref. 9017045

Protection rubber for boom

To soften the contact in case of shock on a vehicle.

To make the boom more visible.

May be put on the lower and / or upper boom's edge.

Supplied in 12 m roll with 4 end caps.



Ref. 9017043

Anchor base for barrier foundation

For a robust fixation of the barrier.

To be sealed in a concrete foundation.



Ref. 9017044

Rest fork

To support the boom's end when the movement is over.

Release static efforts on barrier mechanics for a better lifetime.

To be sealed in a concrete foundation.



Ref. 9017210

Columns for photocells Master Pro (For gates and barriers)

To hold photocells in place at a remote distance from the barrier.

Photocells beam 50 cm above the ground.

Hollow structure for cables to run inside the column.

Fixation by 4 screws (not supplied).



SPARE PARTS	
Ref. 1782267	Spring Levixo 30 (For Levixo 30)
Ref. 1782268	Spring Levixo 50 (For Levixo 50)
Ref. 1782269	Electrical motor
Ref. 1782270	Motor + gearbox Levixo 30
Ref. 1782271	Motor + gearbox Levixo 50
Ref. 1782272	End limits kit
Ref. 1782273	Unlocking kit: Lock mechanism + 2 keys
Ref. 1782274	Electronic box Levixo RTS
Ref. 1782275	Boom fixation kit